

TAPING MODULE

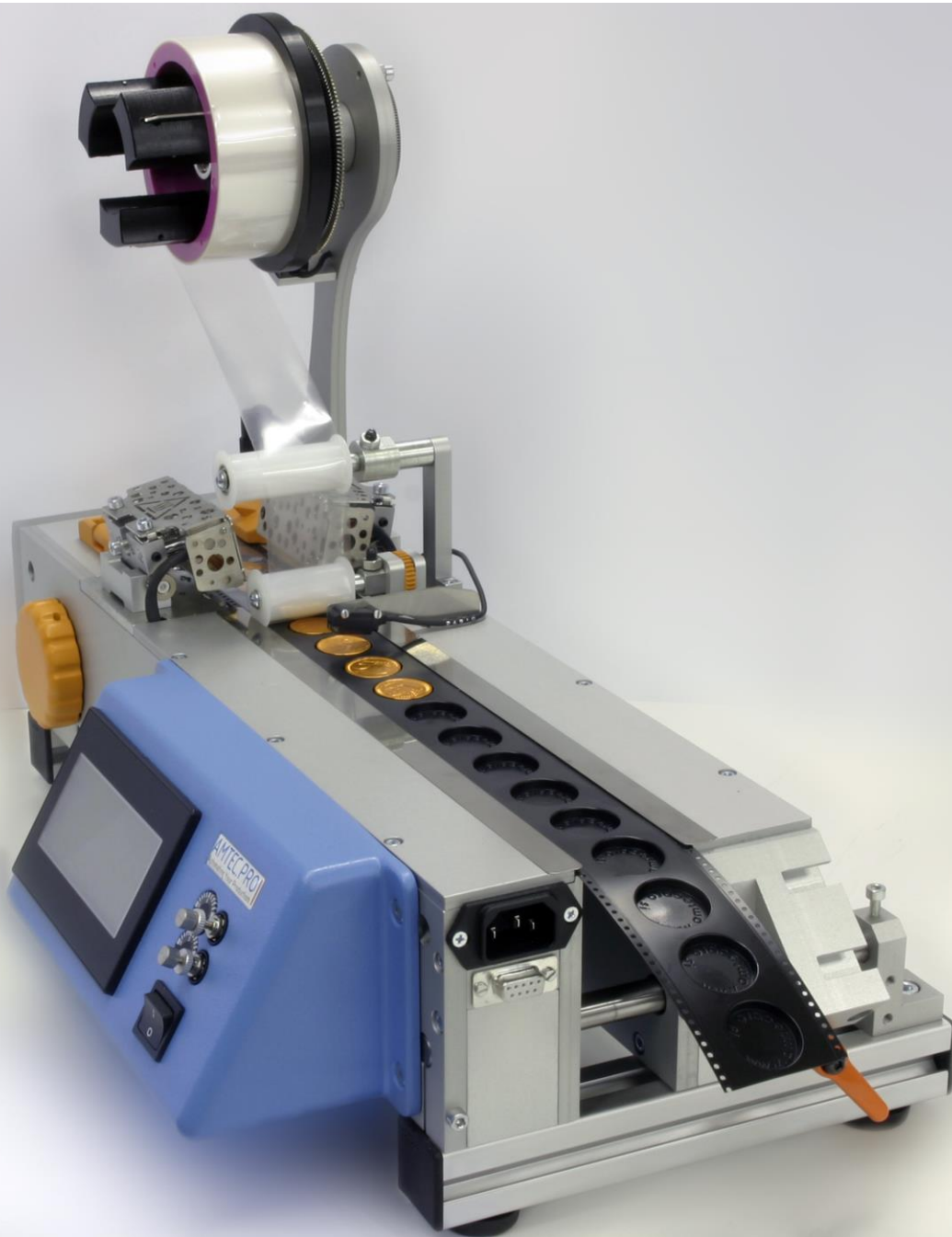

- In-Line integration
- Standalone unit
- Minimum footprint
- Automated working cycle
- Heat Activated cover tape
- Pressure Sensitive Adhesive cover tape
- Adjustable width
- Touch Screen Operator terminal
- Intuitive setup
- Three color display
- Welding parameters separate for each side
- Manual or electronic pressure regulator
- Part presence sensor
- Vision connector
- Various configuration available.

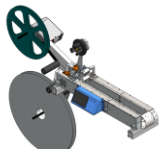
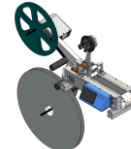
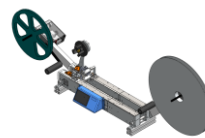
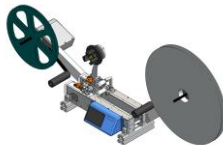
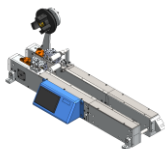

Touch Screen Operation

Basic information display: counter, current/set temperature and working mode.

Three colour backlight signaling machine state:

- Green – normal operation
- Orange – warning (limited operation)
- Red – malfunction (stopped)

Setup menu provide settings as:

- Temperature adjustment
- Pitch adjustment
- Welding type – time – cycle
- Trailer/Fill in/ Leader quantity
- ... and many more ...



Stepper Drive

Stepper motor with encoder closed loop provide highly accurate positioning and automatic error correction in case of tape blockage. Positioning resolution 0,05mm.

Easy load tape procedure enable lift-up sprocket wheel cover

Dual drive for double sprocket carrier tapes.

Heater block & Welding

Fast exchangeable heater block.

Welding position set with positioning screw (optional micrometer)

Protection for hot areas.

Adjustable temperature and welding pressure for each heater block.

Continuous and Step weld mode.

Suitable also for PSA cover tapes



Cover Tape Guide Rollers

Lift up system help operator to set the cover tape easily.

Cover tape position adjustment integrated on the guide roller. With turning the wheel operator can fine adjust position of the wheel.

Fast changeable guide rollers for different cover tape width.

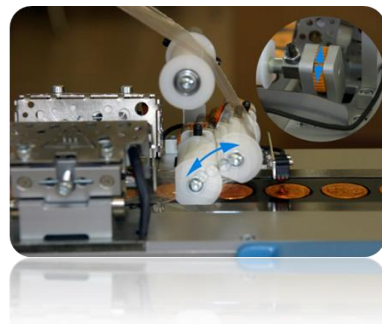

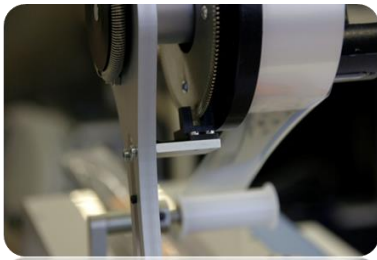

Cover Tape End / Near End Function

Intelligent sensing technology allows operator warnings according to the minimum required cover tape length.

When cover tape run out the machine automatically stop.

Constant tension of cover tape is provided by innovative design of tension mechanism.

Part Presence Detection

Part presence sensor integrated.

In combination with working mode detects cavity status (filled, empty). In case of nonconformity stops the machine and warn the operator.

Optional vision checker for orientation detection.

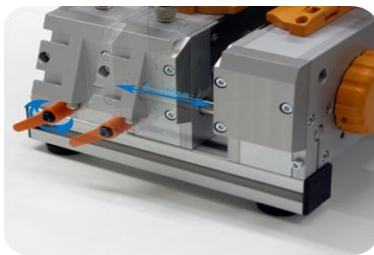

Adjustable Width

All units have adjustable width, while fixed units have possibility of micro adjustment according to the carrier tape tolerance, variable units can be adjusted for all types of carrier tapes.

Width adjustment depends on the model.

Technical Dat

- Tape width: 8-200mm
- Tape pitch: 2-72mm
- Max pocket depth: 40mm
- Temperature control:
Dual control with digital readout
30°C ÷ 250°C
- Electrical supply:
230VAC, 2A
24VDC, 4A
- Compressed air supply: 6bar, 10l/min
- I/O signals:
Ext. Start (input 24VDC, active high)
Ready (output 24VDC, active high)
Status (3x output 24VDC, active high)

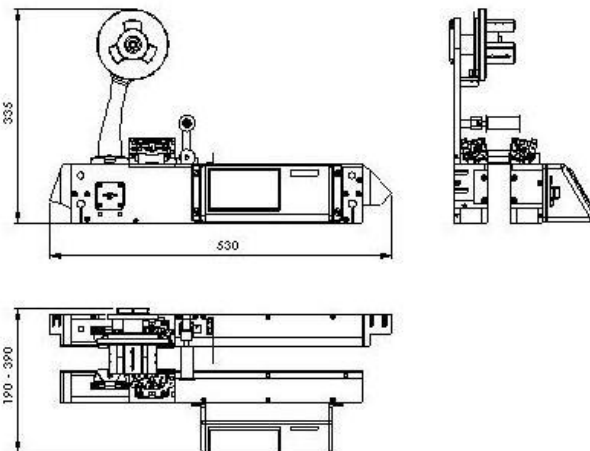

Modbus TCP/IP

Weight: 9kg

ORDER SPECIFICATIONS

Taping Module

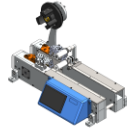

Art. No. 910XXX

| | |
|---|---|
| <input type="checkbox"/> 8mm ÷ 56mm (single sprocket drive) | <input type="checkbox"/> 8mm ÷ 200+mm (dual sprocket drive) |
|---|---|

OPTIONS

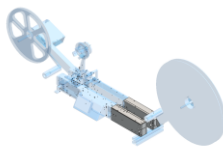

Art. No. 912001
Elongation
 250mm

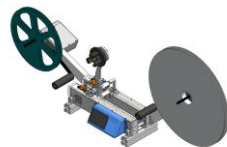

Art. No. 913001
 linear

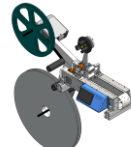

Art. No. 913002
Tape path
 inverted



Art. No. 914001
Configuration
 mirrored

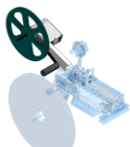

Art. No. 915001
Rewinding
 max. 15" reel



Art. No. 916002
Rewinding
 max. 21" reel

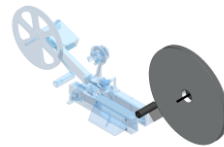

Art. No. 917001
Unwinding
 single reel

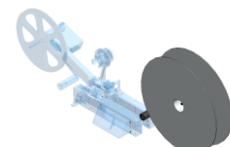

Art. No. 917002
Unwinding
 cross winding

For any kind of configuration not described please contact us directly. For an automated system please send requirement with part specifications.