

FADOS9F1 & FADOS XI Advanced VI Analyzer

Multi-Functional Circuit Board Tester

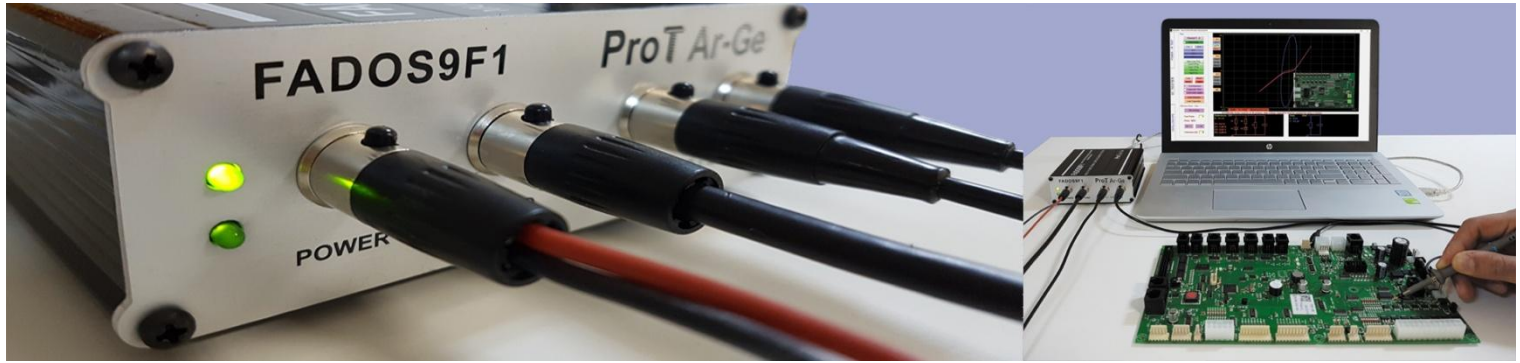

Easiest Way to Find Faults on Electronic Cards is to Use FADOS

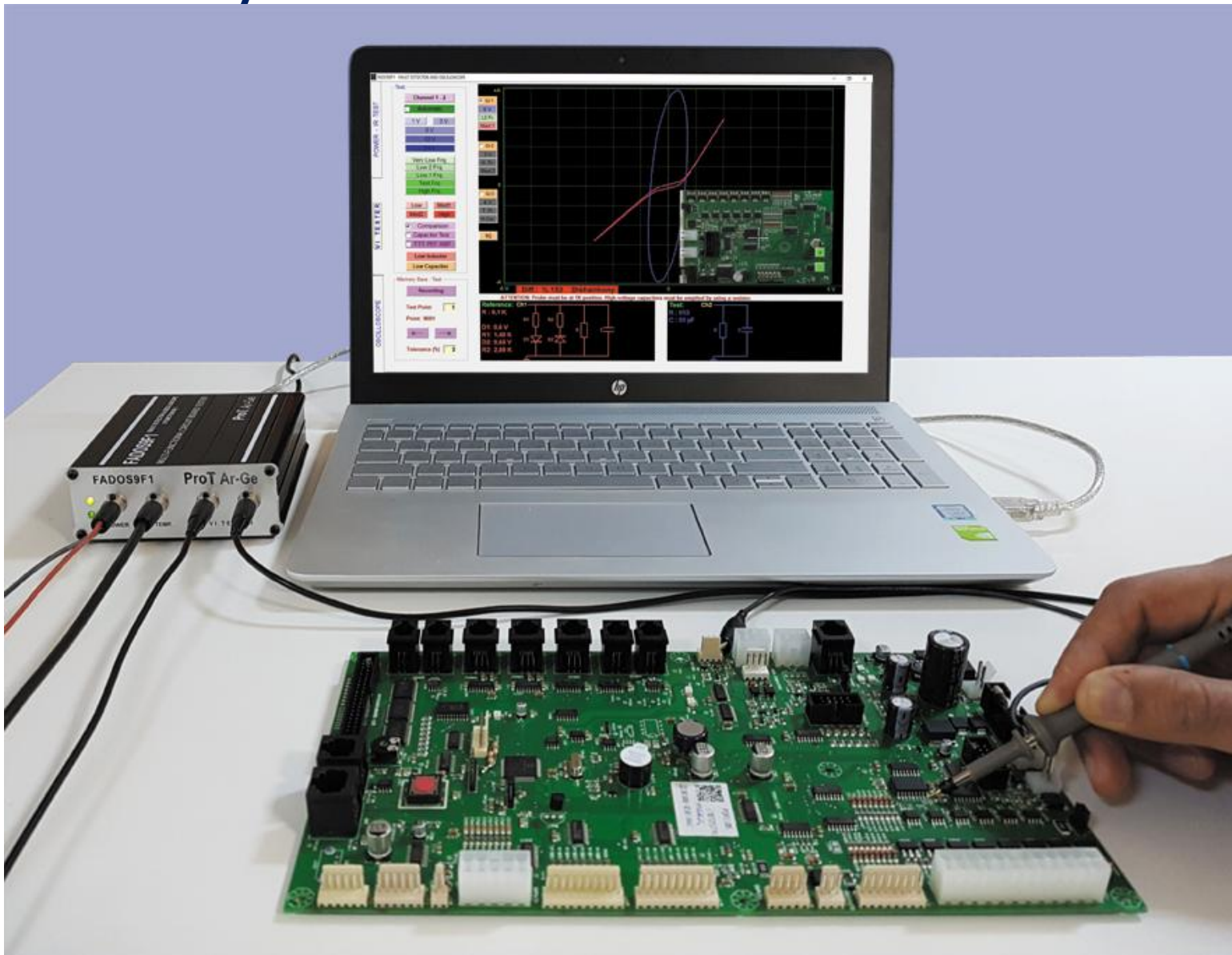

FADOS9F1 Multi-functional Circuit Board Tester

FADOS9F1 & FADOS XI Advanced VI Analyzer Features:

- Dual Channel Fault Detection by VI Tester
- Comparison with Stored Signatures (Memory)
- Equivalent Circuit Diagram
- Display Values of Resistor, Capacitor, Inductor and Diode
- Adjustable DC Power Supply, and power VI graph
- Non Touched IR Temperature Sensor
- Automatic voltage, current, and frequency adjustment.
- Automatic 1V screen.
- Additional functions: Oscilloscope, Square Wave Signal, and Analog Voltage Output.
- Fault reporting in Excel and JPG formats.

FADOS XI Advanced VI Analyzer Additional Features:

- Non-contact Short Circuit Detection Sensor
- Step-by-step Frequency Scanning (50 – 1250Hz, 100 – 2500 Hz)

The Development of FADOS:

FADOS is a brand inspired by the abbreviation of the words "**F**ault **D**etector **O**scilloscope." From its inception, this product aimed to combine many functions in one device, eliminating the need for different tools for repair technicians who might encounter problems diagnosing faults on electronic circuit boards. Our goal was to develop a small, portable, and practical product.

The first device we developed was slightly larger than a matchbox, quite small for a device in a plastic case, but with revolutionary features. These features included generating the equivalent circuit diagram of the point of contact and instantly measuring the values of all components. These are unique features developed by us. We named it FADOS7F1. Then, we added an infrared heat sensor feature to power the board and detect components drawing excessive current, and we named this FADOS9F1.

FADOS9F1 & FADOS XI Advanced Product and Package Contents

- 1 FADOS9F1 Product
- 1 Software
- 1 IR Temperature Probe
- Non-contact Short Circuit Detection Sensor (Only Adv. Model)
- 2 Oscilloscope Probe
- 1 USB Cable
- 1 DC Cable
- 1 Power Adaptor
- 1 FADOS9F1 Handbag
- Short Circuit Detection Sensor (FADOS XI Advanced VI Analyzer Model)

COMPARATIVE TEST OF THE MATERIALS IN THE ELECTRONIC CIRCUITS

The comparison feature; the user can detect the fault by testing solid and defective cards at the same time. Channel 1 (red) is the solid card signal, Channel 2 (blue) is the defective card signal. The difference in the curves means that there is a fault in the integrated pin of the defective card.

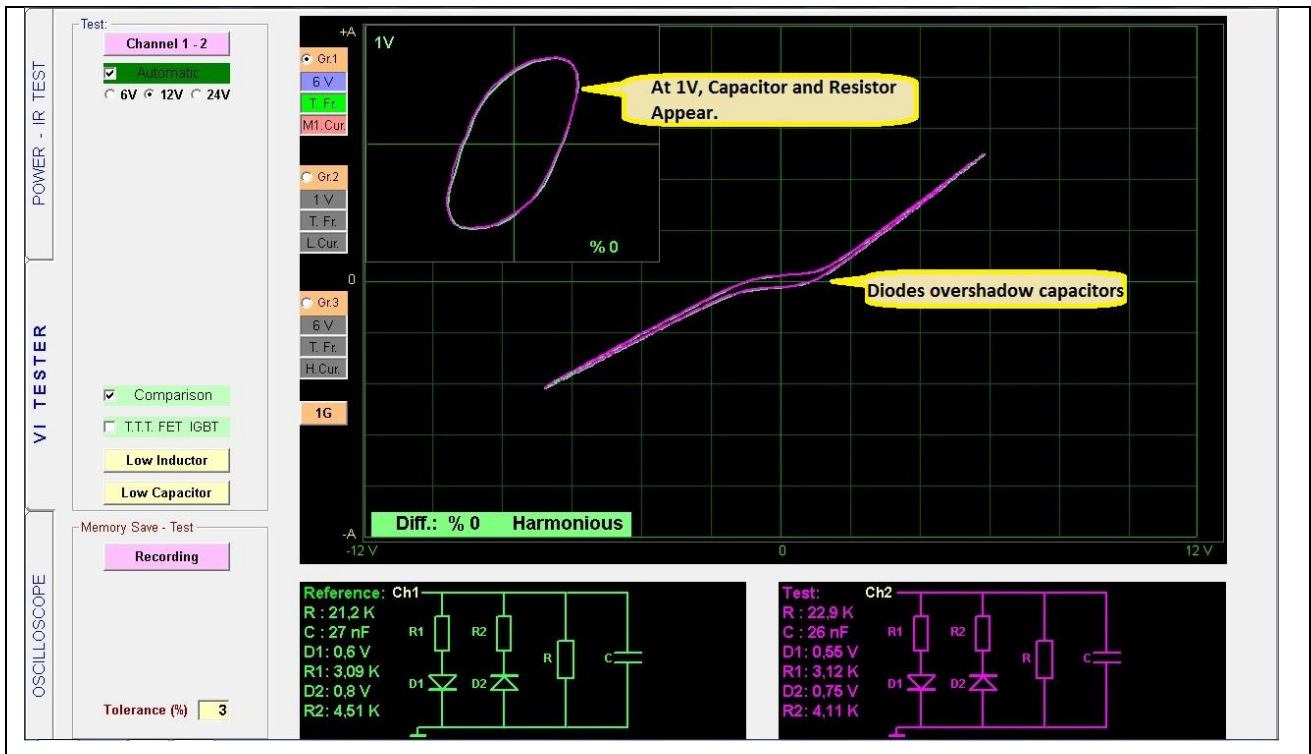

Dual Channel VI Graph, Equivalent Circuit Drawing and Multi-Value Display Features

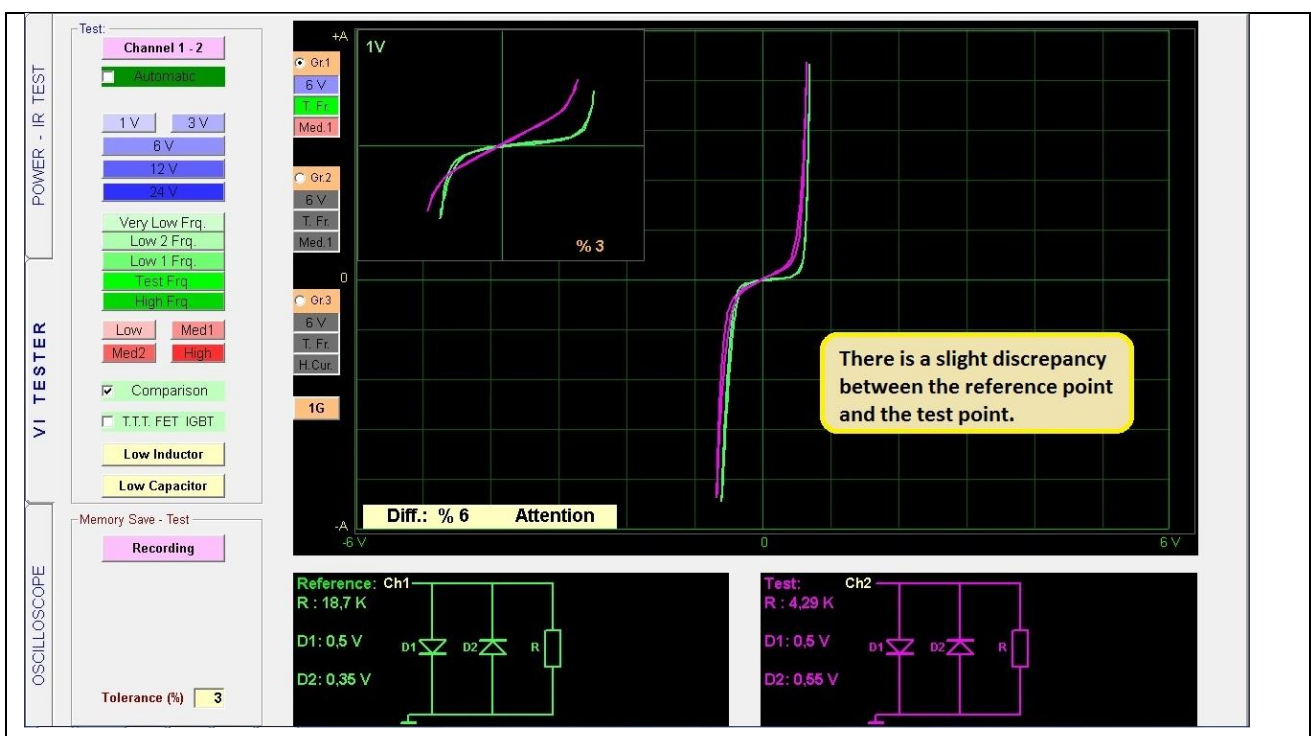

Comparison Testing Component of Circuit Boards with Picture from Memory

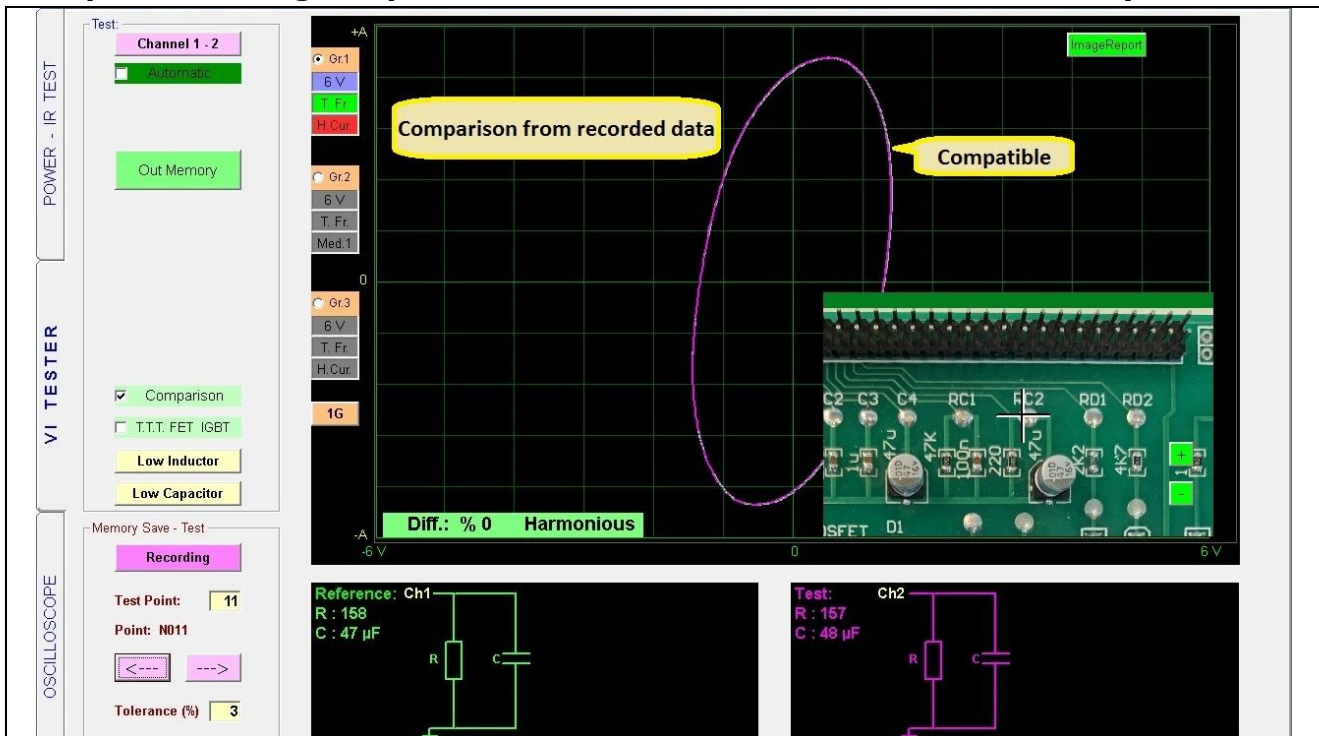

Circuit Node is displayed in the display with crosshairs cursor

Memory Recording feature; by means of this feature, the characteristics of the intact electronic circuit board (VI graph, equivalent circuit diagram and electronic components values) are written on the computer's hard disk and taking these points as reference, you can compare the defective (or assumed to be defective) electronic circuit boards accurately, easily and rapidly. At the same time, the data can be written on the photograph of the board. Thus, the recorded point can be seen on the photograph while making a comparison from the memory.

The software **produces different sounds** while **comparing** the **matching** and **non-matching** points during the test. Thus, the comparison can be made rapidly by focusing on the sounds without looking at the display constantly.

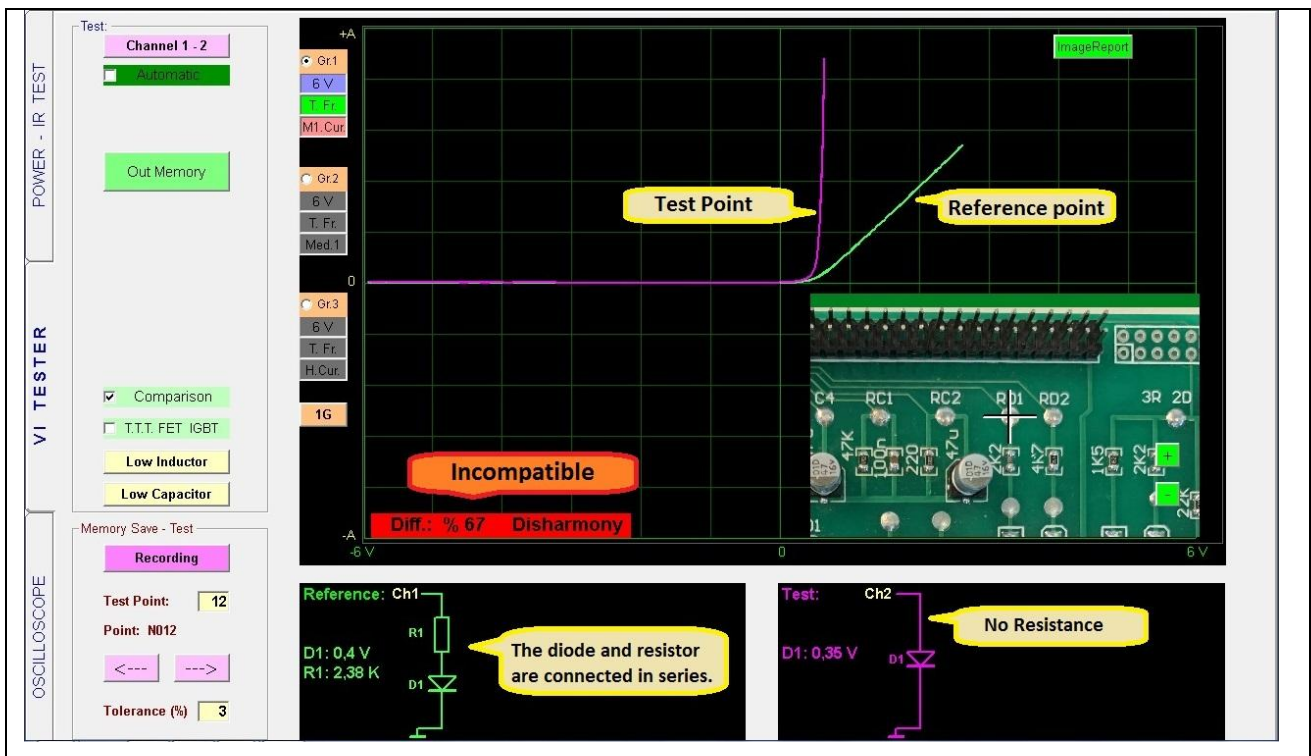

The faulty component can be quickly detected using the Memory Recording feature.

Power (Supply) - IR Temperature Test

Energize the electronic circuit board in the Power (Energy) - IR Temperature Test section to generate a DC V-I Graph. Thus the amount of current drawn by the board can be seen. Moreover, the temperature of the electronic components may also be measured using the IR (Infrared) Sensor.

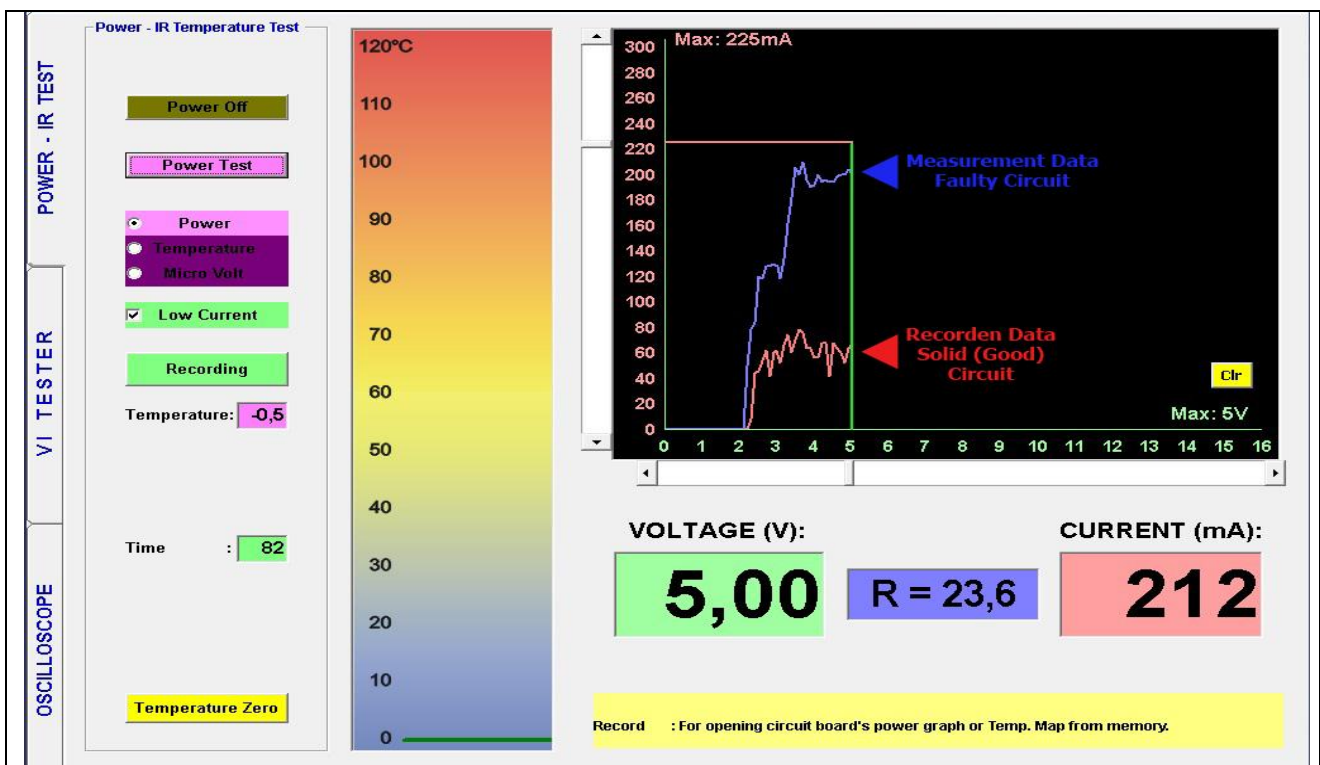

If the defective electronic circuit board draws more current than the intact (working) electronic circuit board this means that one or more components on the board are drawing current. The component that draws current heats up. The IR Sensor is used for diagnosing the heating components.

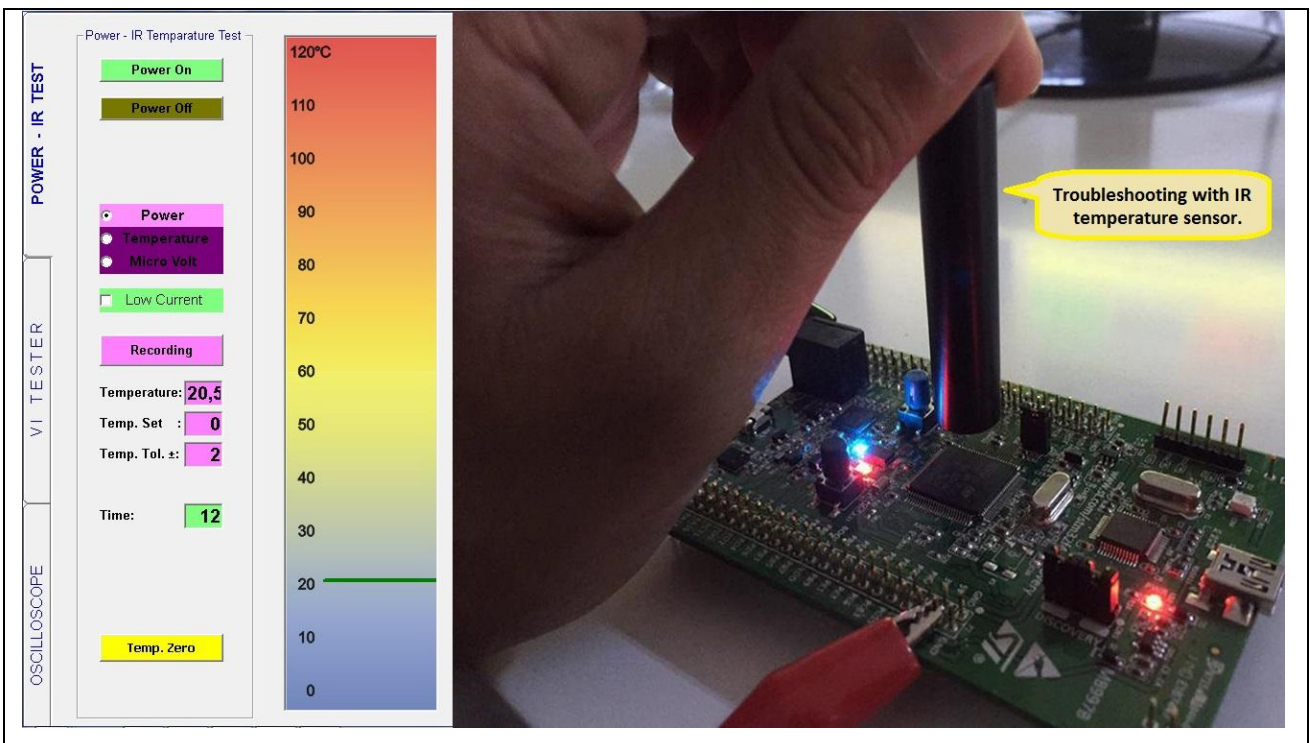

IR Sensor Component Temperature Measurement

Resistor V-I Graph

The **Resistor** V-I graph is always a straight line between 0 and 90 degrees to the X axis. Resistor symbol and value are seen at the bottom of the graph.



Capacitor and Inductor V-I Graph

The **Capacitor** graph is an ellipse or a circle. The **Inductor** graph is elliptical or circular; due to the resistance of the wires in the inductor, the effect of the resistors is also observed in the graph.

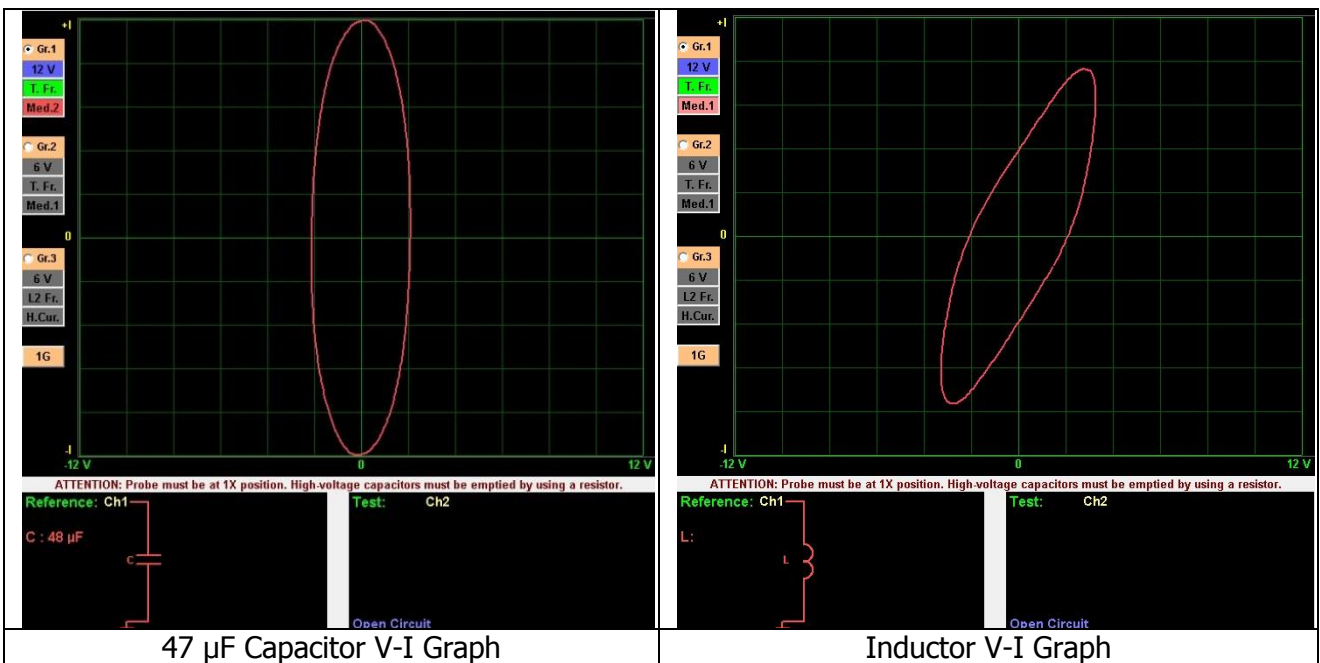

Capacity Quality Test

The Capacitor failures caused by leaking in the capacitor in general and as a result, the capacitor acts as if a resistor is connected in parallel. The quality of the leaky capacitors is decreased. The leaky capacitors can be identified easily thanks to the capacity test characteristics of the FADOS9F1.

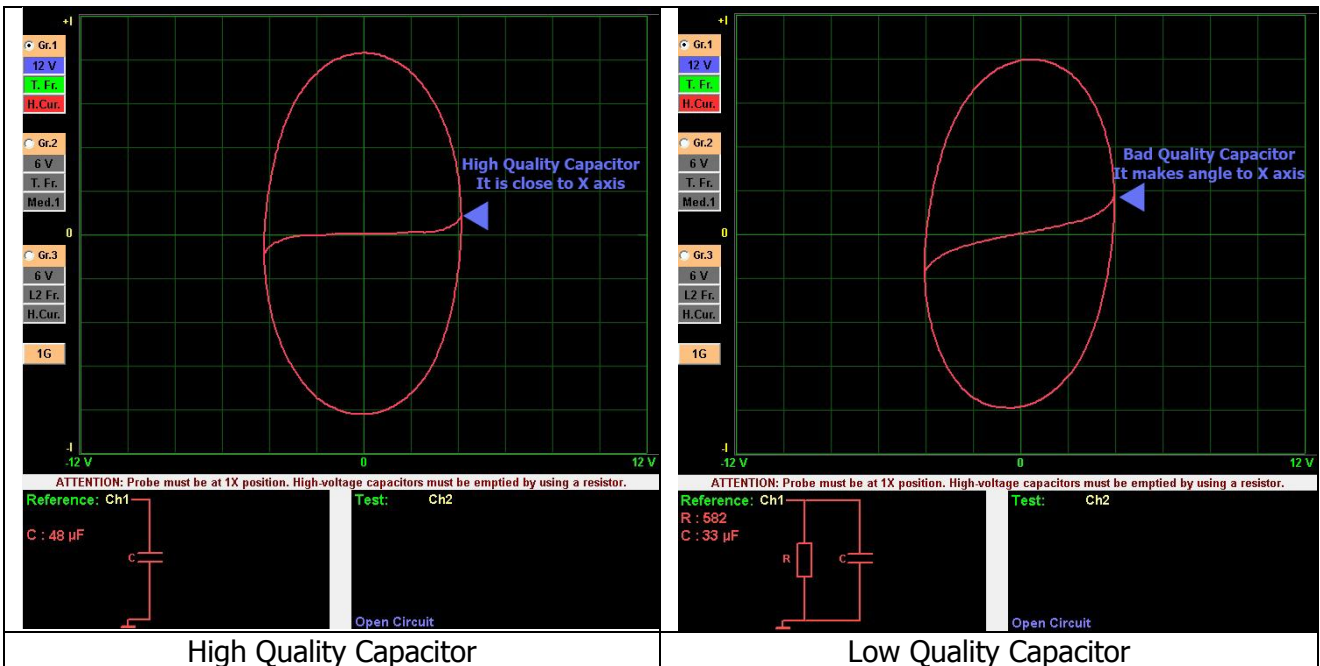

Diode – Zener Diode V-I Graph

The semi conductor **Diode** graph appears as one or more straight lines with a 90 degree angle in between.

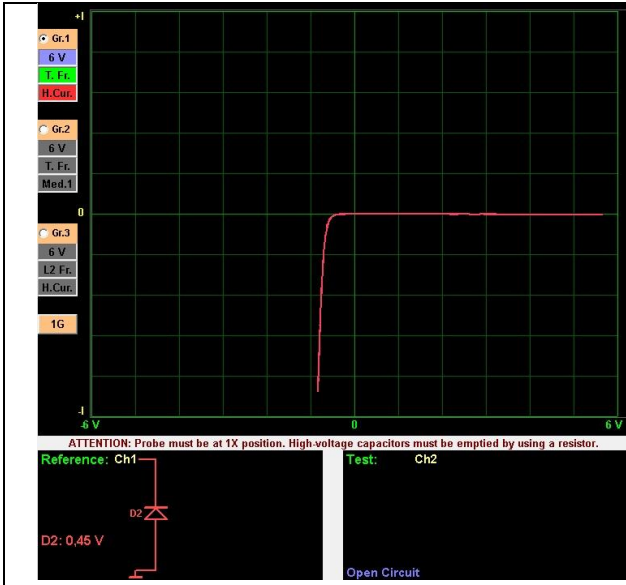

Diode V-I Graph

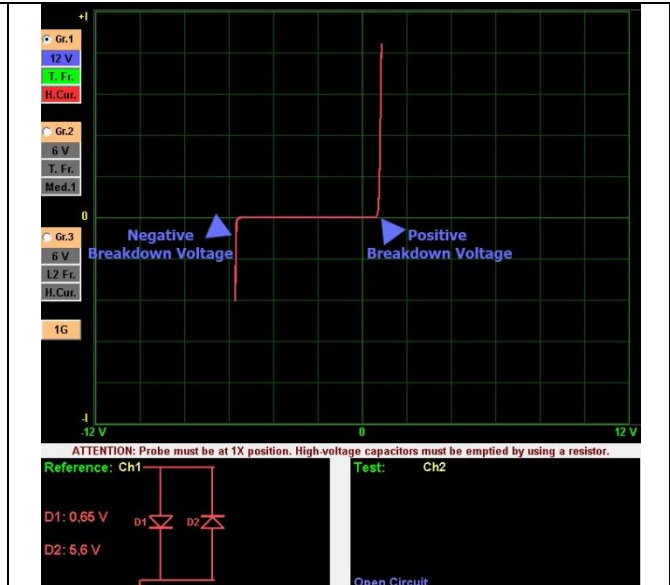

Zener Diode V-I Graph

Transistor – Triac – Thyristor (SCR) – FET – IGBT – Opto-Coupler V-I Graph

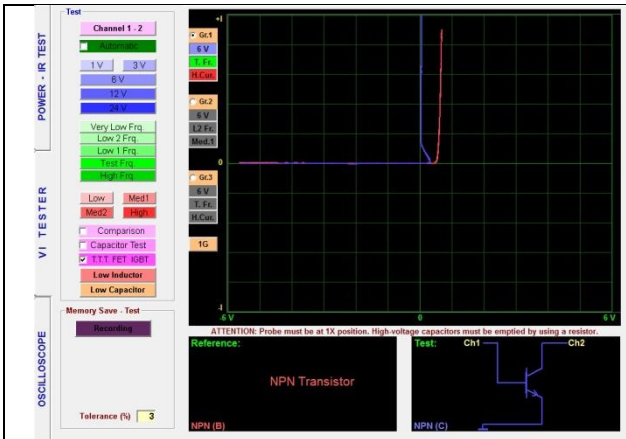

NPN Transistor V-I Graph

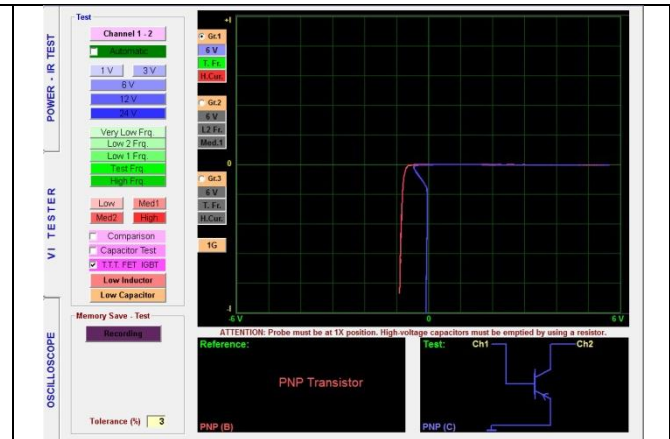

PNP Transistor V-I Graph

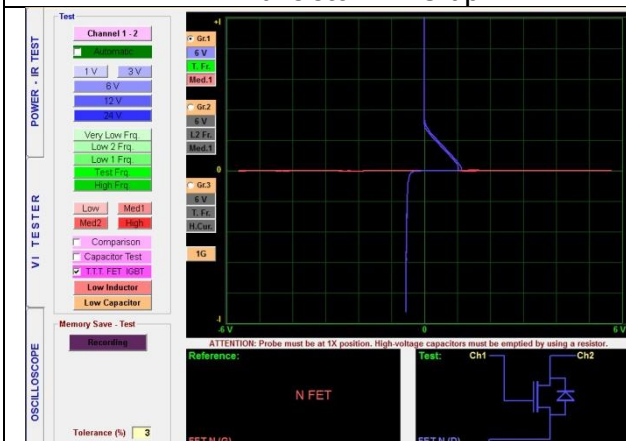

N FET V-I Graph

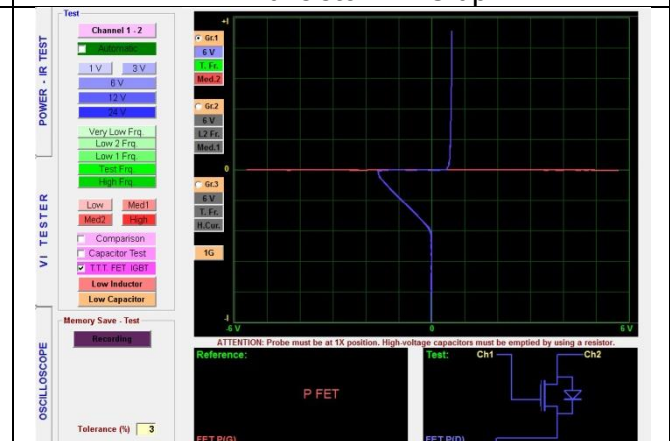

P FET V-I Graph

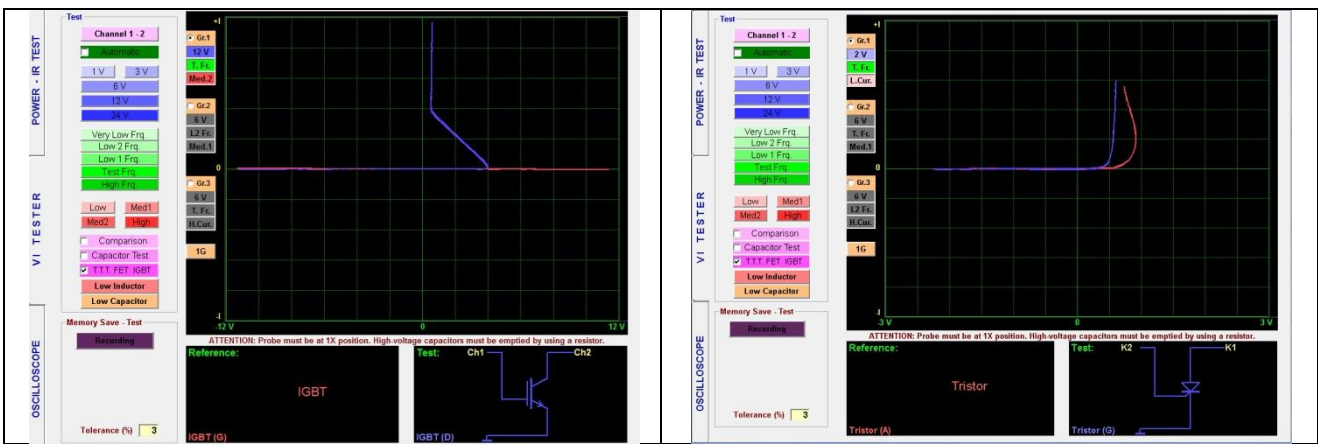

IGBT V-I Graph

Thyristor (SCR) V-I Graph

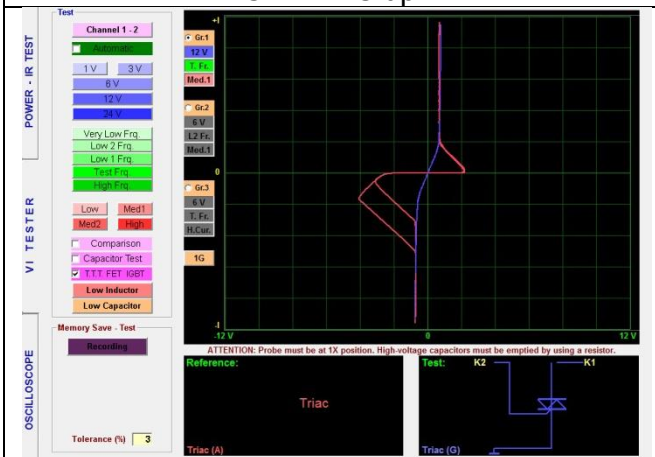

Triac V-I Graph

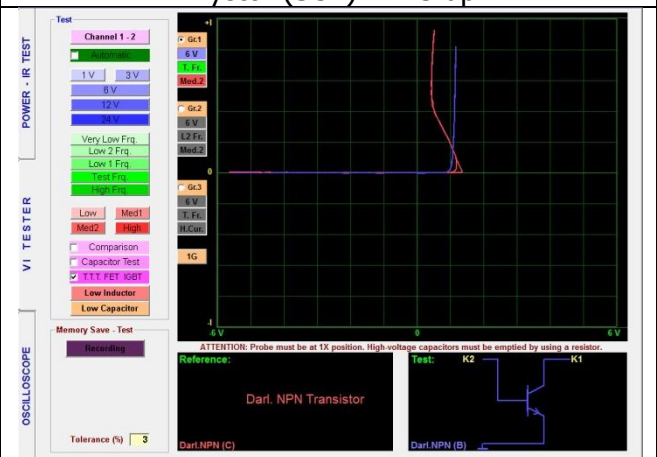

Opto-Coupler V-I Graph

Integrated Circuits (ICs – SMD Integrated Circuit Tests)

The Integrated circuits are composed of the semi conductor components and protective zener diodes and or diodes are connected to all the pins for protection. Therefore, when the integrated circuits are tested, their V-I graphs resemble the zener diodes or normal diodes. The VI graph of the Integrated circuit Vcc pin resembles the graph of a diode and a capacitor connected in parallel. The graph of a short circuit is displayed for the GND pin.

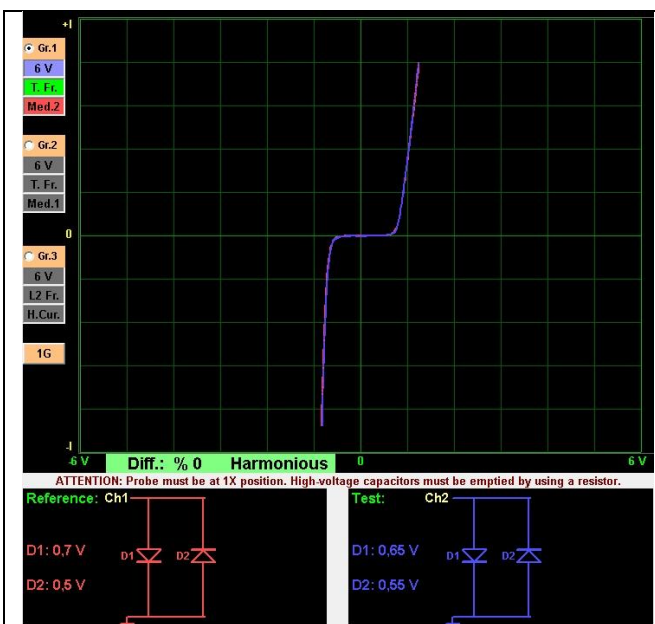

74LS02 IC Output V-I Graph Comparisons Against Each Other

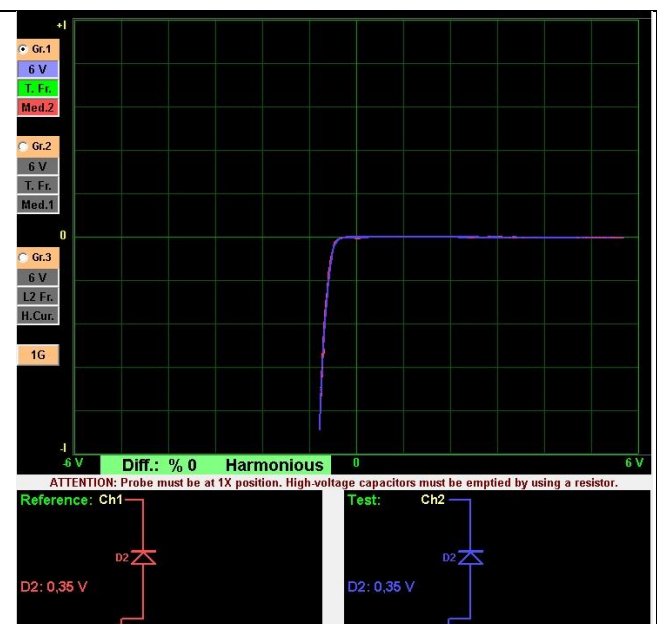

74LS02 IC Input V-I Graph Comparisons Against Each Other

3G – Display of The Graphs For 3 Different Settings

The FADOS9F1 can make comparisons on the electronic circuit boards at 3 different settings simultaneously. By clicking the 1G button, the failure diagnostics screen 2G, that is Gr.1 and Gr.2 active graph, and in 3G the Gr.1, Gr.2 and Gr.3 can be displayed by selecting different voltage, frequency and current stages. Using this method, the response of the electronic component against different voltage, frequency and current stages can be observed. E.g. while some electronic material's graph may appear intact under low current, it may prove to be defective under high current.

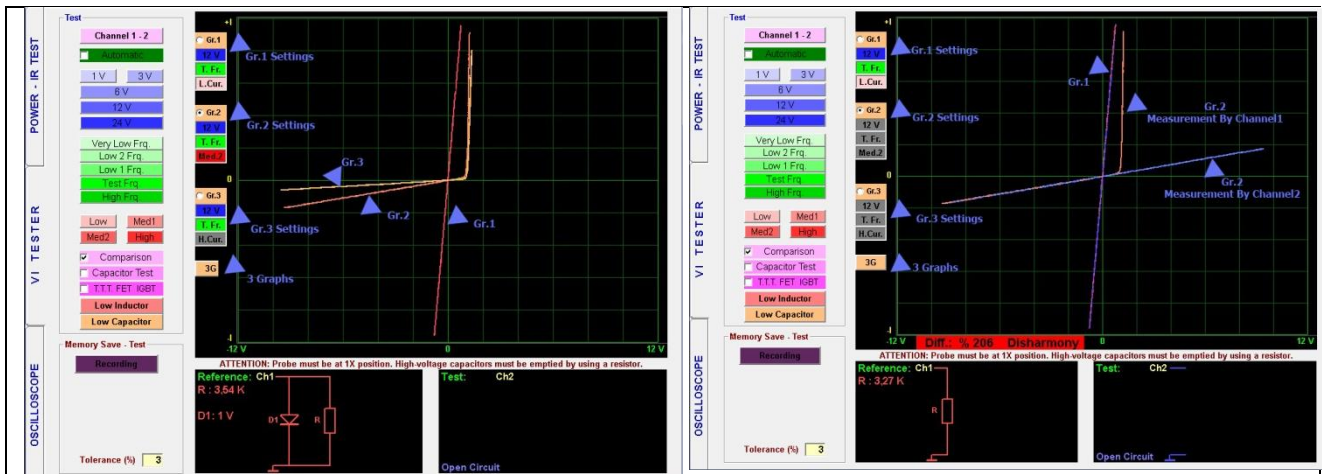

Fault Detection Techniques in Electronic Cards

Those who are new to electronic repair usually use a multimeter to measure the resistance, capacitance or diode conduction voltage of the materials and perform tests or fault detection. Since this method is both time-consuming and insufficient in some respects, more professional ones usually prefer VI test devices. VI test devices display resistance, capacitance or diode together graphically. The first advantage is to check the touched point in a short time. The second advantage is that they apply a higher voltage than multimeters through a resistance, so they do not damage the circuit and make the differences that occur at higher voltages visible.

Some of the VI test devices only have a VI curve. More advanced ones may have different functions. For example; those with a memory feature may have the feature of recording the touched points and then comparing them with the defective card.

There are many features in FADOS devices that can be very useful to the user in finding faults. Some of these features are specific to FADOS devices. These features are the equivalent circuit diagram display and the ability to show the values of circuit elements. For example, if there is a parallel resistance at the same point while measuring a capacitor with a multimeter, the multimeter will not show the capacitor value correctly or will not measure it at all. FADOS software shows both the value of the capacitor and the resistance at the same time. Such features help the user to find the fault faster. The memory recording and memory comparison feature is quite useful. Thanks to this feature, it shows which point you should touch from the photo. If it is within the set tolerance when you touch, it gives you a sound meaning "OK" and when you lift your hand, it automatically moves to the next point. If it is out of tolerance, it warns with a different sound and it is understood that that point has a different value than the working reference device.

Usage Areas

ECU Automotive electronic cards, servo - stepper motor drivers, medical and military electronic device cards, computer - laptop and monitor circuits, television - radio electronic cards, auto electronics, textile and other production machine electronic cards etc. (in all electronic cards)

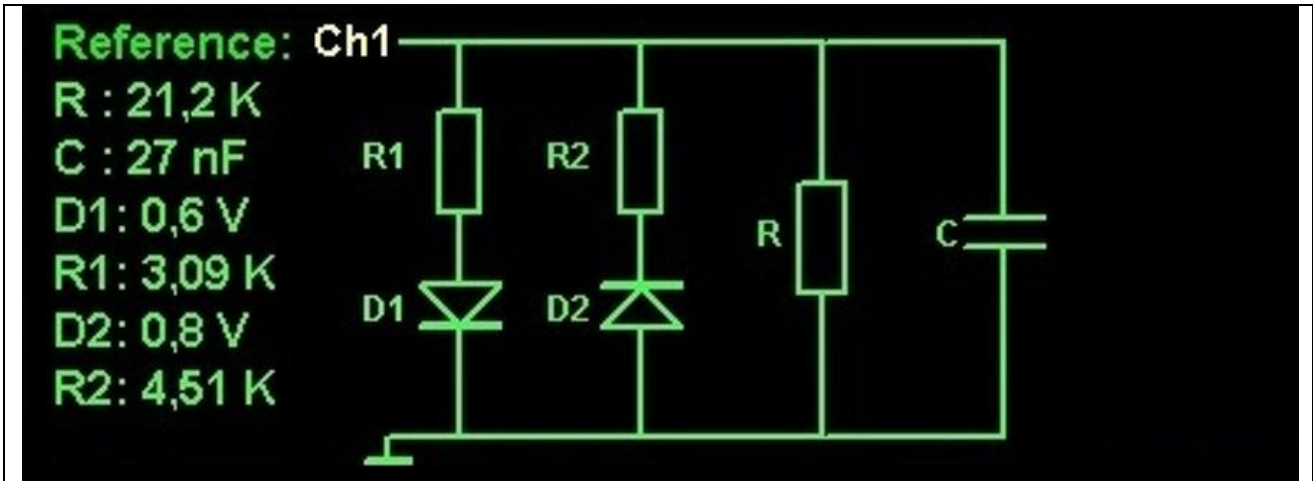

**Are you measuring the components one by one?
Touch and see everything instantly.**

Equivalent Circuit Diagram and Measuring Values of Electronic Components

FADOS XI Advanced VI Analyzer

Additional Features

Short Circuit Finder:

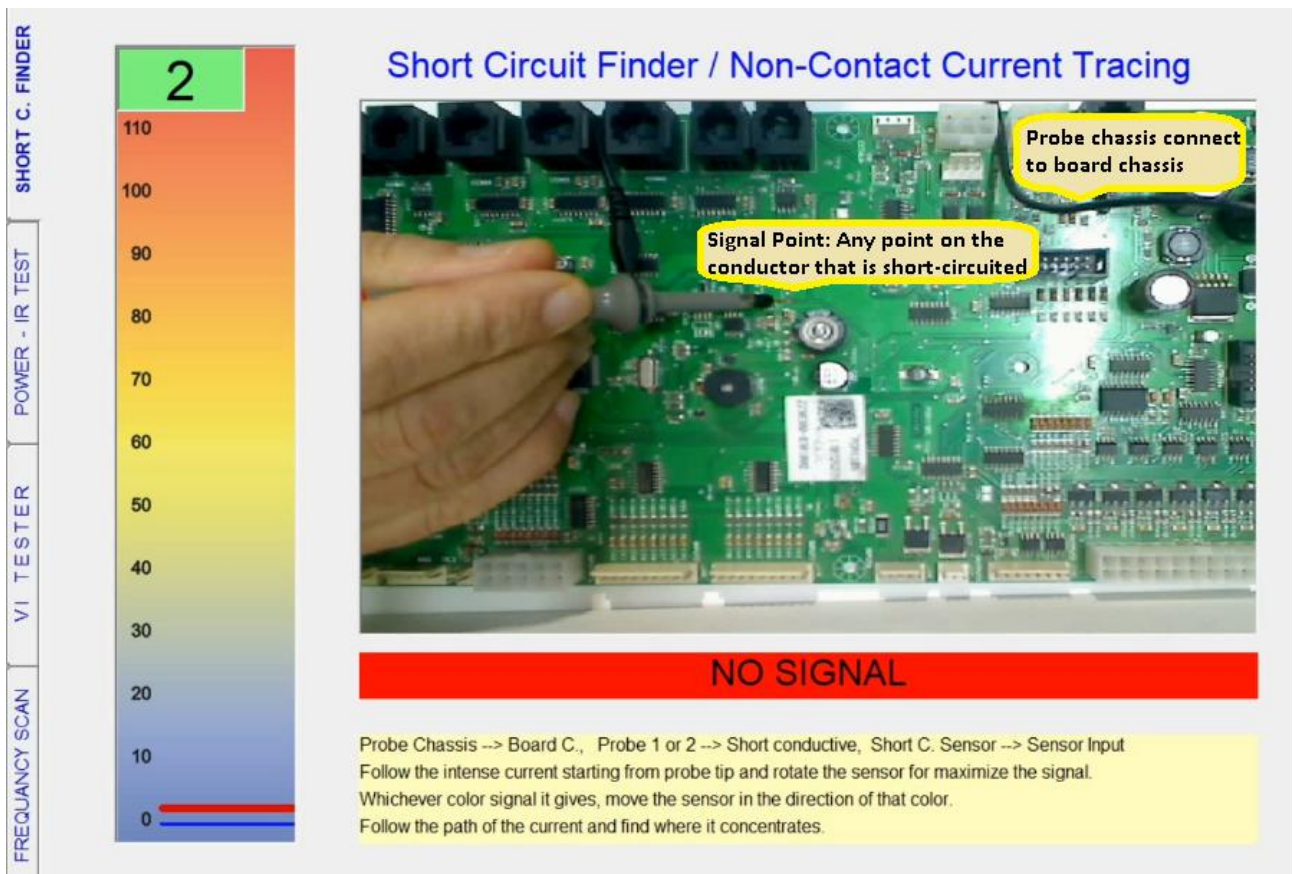

SHORT C. FINDER

POWER - IR TEST

VI TESTER

FREQUENCY SCAN

2

110

100

90

80

70

60

50

40

30

20

10

0

Short Circuit Finder / Non-Contact Current Tracing

Probe chassis connect to board chassis

Signal Point: Any point on the conductor that is short-circuited

NO SIGNAL

Probe Chassis --> Board C., Probe 1 or 2 --> Short conductive, Short C. Sensor --> Sensor Input
Follow the intense current starting from probe tip and rotate the sensor for maximize the signal.
Whichever color signal it gives, move the sensor in the direction of that color.
Follow the path of the current and find where it concentrates.

The probe's ground is connected to the circuit board's ground. The probe's tip applies a signal to either side of the short-circuited conductor. This signal causes current to flow along the short-circuited path.

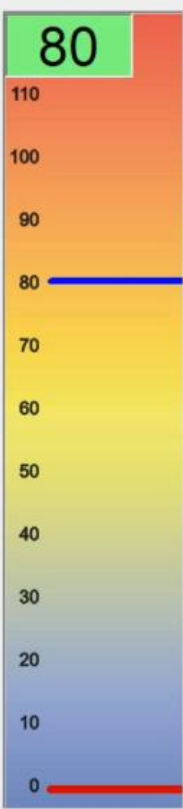

Short Circuit Finder / Non-Contact Current Tracing



NEAR The CURRENT WIRE or SHORT C.

Probe Chassis --> Board C., Probe 1 or 2 --> Short conductive, Short C. Sensor --> Sensor Input
 Follow the intense current starting from probe tip and rotate the sensor for maximize the signal.
 Whichever color signal it gives, move the sensor in the direction of that color.
 Follow the path of the current and find where it concentrates.

A short circuit sensor tracks the path of current, allowing you to locate the short circuit. Starting from the tip of the probe, locate the point where the signal is strongest. The current sensor is directionally sensitive. When it gives a signal, rotate it slightly to find the position where the signal is strongest. If the red line is upwards and giving a signal, move towards the red side of the probe, if it gives a blue signal, move towards the blue side.

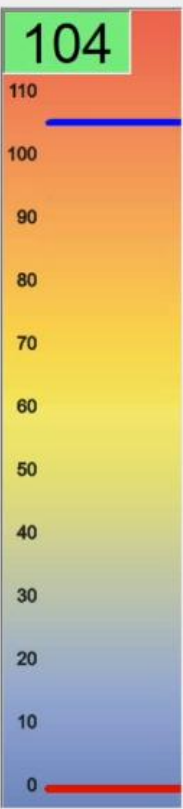

Short Circuit Finder / Non-Contact Current Tracing

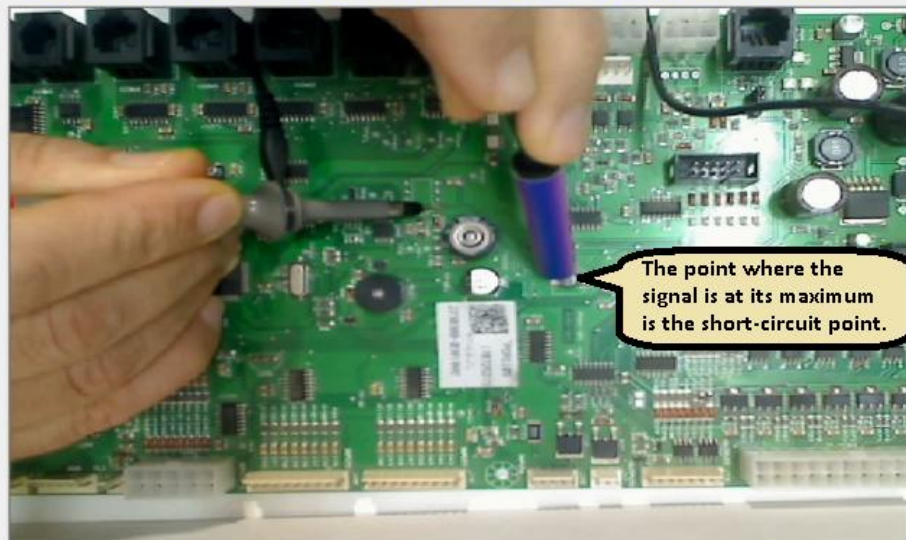

CURRENT WIRE or SHORT CIRCUIT

Probe Chassis --> Board C., Probe 1 or 2 --> Short conductive, Short C. Sensor --> Sensor Input
 Follow the intense current starting from probe tip and rotate the sensor for maximize the signal.
 Whichever color signal it gives, move the sensor in the direction of that color.
 Follow the path of the current and find where it concentrates.

By tracing the path of the current, the point where the signal is maximum is found. This point is the short-circuit point, and generally, after this point, the signal weakens and dissipates. The signal generally does not change abruptly along the conductor, but in the case of a short circuit, small movements can cause sudden changes in the red and blue signal signals. From this, the short circuit point can be identified.

Step-by-step Frequency Scanning:

This property shows how components at a point in the circuit respond to frequency changes. Changes are usually observed at points where capacitors are located. This property can aid in troubleshooting and help designers determine the appropriate capacitor value at a given point.

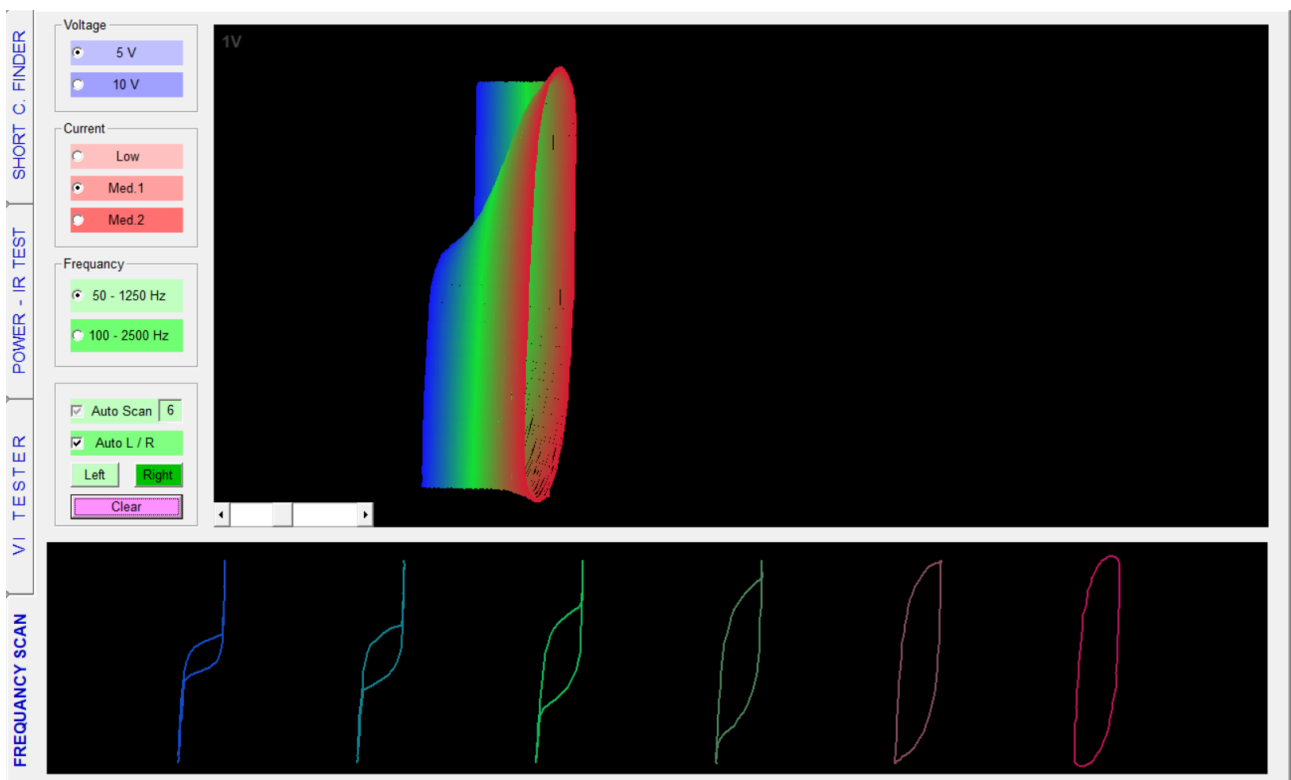

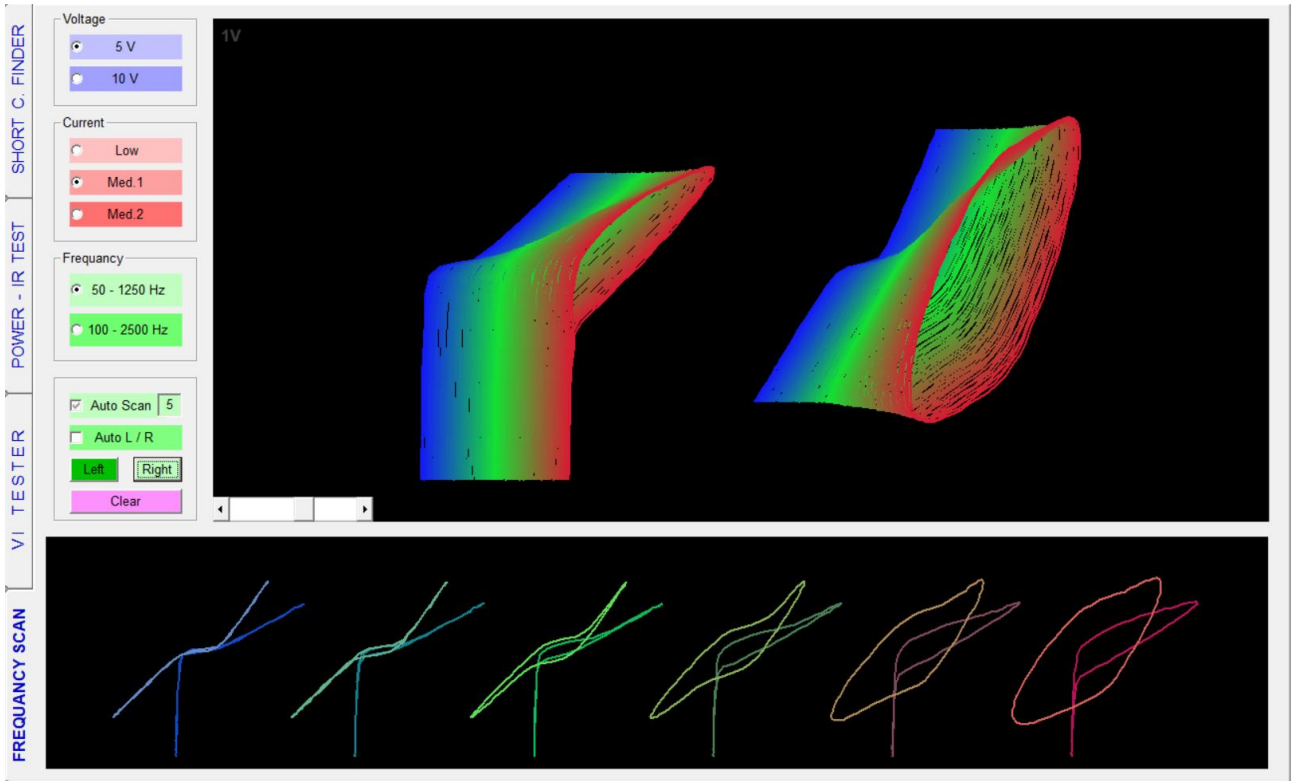
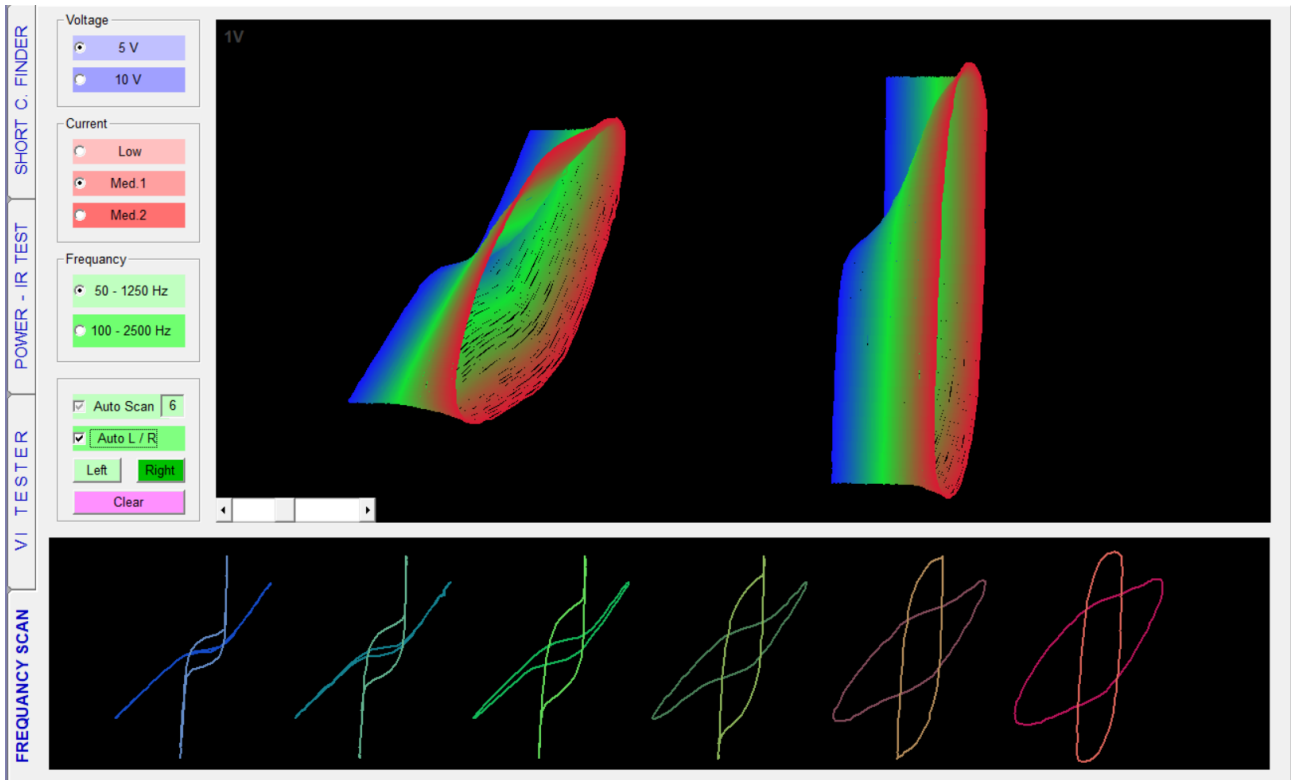

FADOS MUX

Multiplexer Module

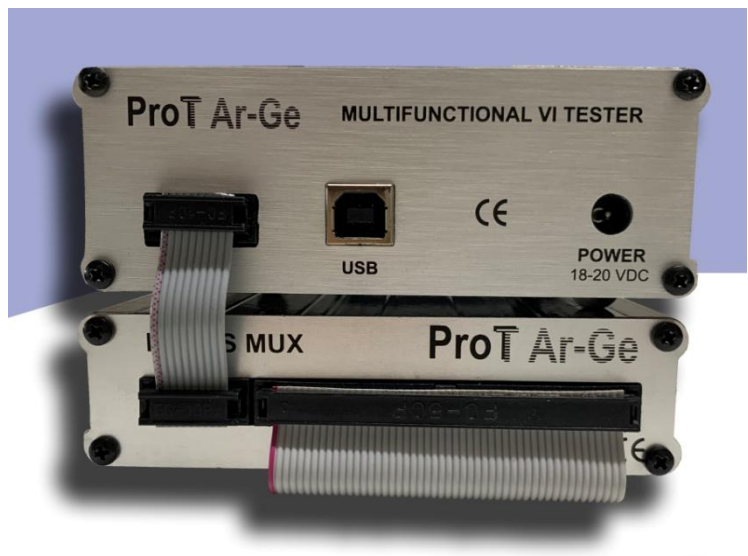

FADOS Multiplexer Module uses for testing and checking electronic circuit boards and finding faulty of electronic components. The main purposes is creates VI graphs of circuit board test points in a while. So; the user measure much tests points in a short time.

FADOS MUX Multiplexer Module works with FADOS9F1 together. It connects to FADOS9F1 with a connector and takes energy from FADOS9F1. FADOS MUX has 96 outputs. The first (front) 48 output is "A" channel; the second (back) 48 output is "B" channel. A - B channels measure at the same time.

FADOS MUX connects parallel to each other so that the output changes according to how many products connect parallel. For example; if 2 FADOS MUX connect parallel the output is $96 \times 2 = 192$.

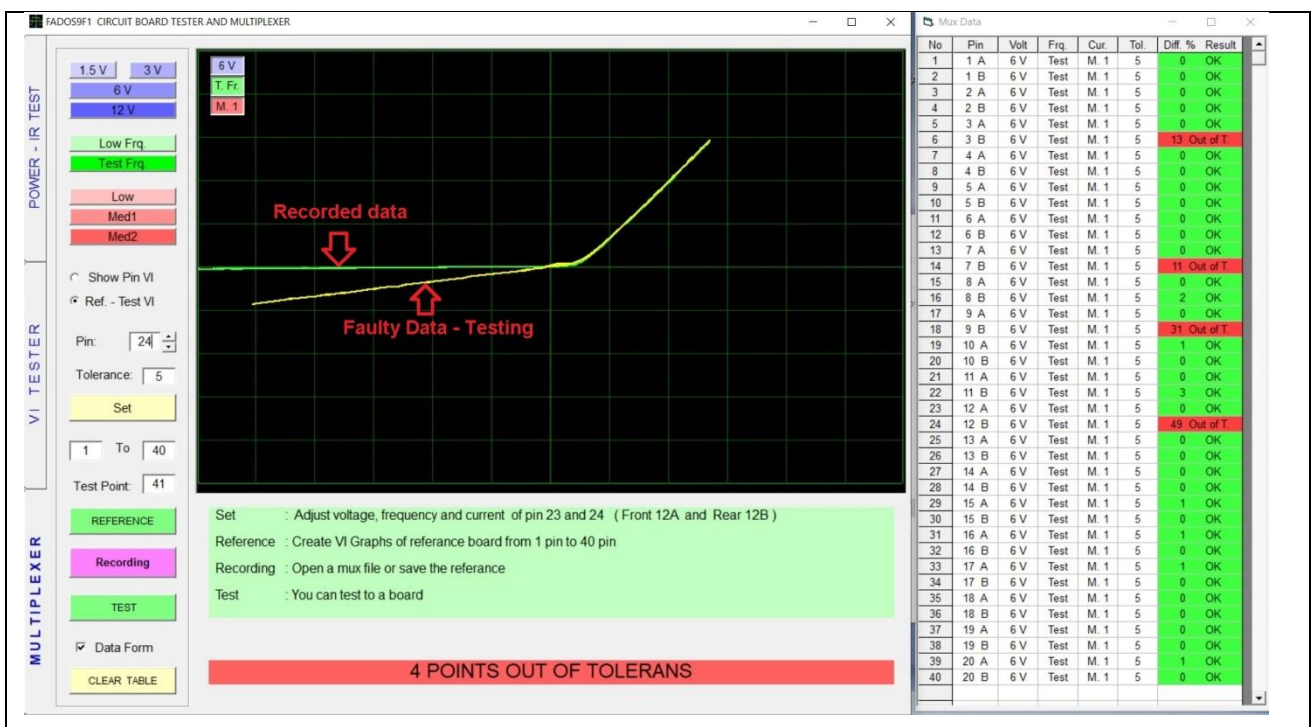

4 Test Points are out of Tolerance

FADOS MUX Multiplexer Module Package Contents

- 1 FADOS MUX Product
- 2x50 pin Connector
- 1x10 pin Connector

FADOS9F1 & FADOS XI ADVANCED VI ANALYZER TECHNICAL SPECIFICATIONS

VI TESTER SPECIFICATIONS:

Voltage	: $\pm 1V, \pm 3V, \pm 6V, \pm 12V, \pm 24V$
Output Resistance	: Low: $47K\Omega$, Med.1: $3,5K\Omega$, Medium2 680Ω , High 240Ω For Inductors: 11Ω
Frequency	: Very Low Frequency : 2, Hz Low2 Frequency : 7 Hz Low1 Frequency : 20 Hz Test Frequency : 55 Hz High Frequency : 2,2 KHz High Frequency (For Inductor) : 7,8 KHz
Number of Channels	: 2
Scan Mode	: Manual and Automatic. Automatic selection steps Voltage, Current and Frequency.
ADC – DAC / Sensibility	: 12 Bit / 6mV

POWER OUTPUT:

Voltage	: 0 – 16V
Current	: 0 – 1.5 A

SOFTWARE : For all Windows compatible computers